



**DIRT BOOK
2016**

ZAP

HANDLEBARS



ZAP FMX-LENKER

- 28.6mm oversize Lenker mit Mittelstrebe
- hochfestes 7075 T6 Ergal Aluminium
- verstärkte Wandung im Bereich der Biegung und Verjüngung für beste Stabilität
- Einstellskala für optimale Positionierung
- kugelgestrahlte, eloxierte Oberfläche für perfektes, haltbares Finish
- polierte Gasgriffseite für minimale Reibung
- kupplungsseitig geriffelt für besten Halt des Griffgummi
- inklusive Lenkerpolster

ZAP FX-Lenker werden von verschiedenen Offroad-Champions im internationalen Motocross und Endurosport gefahren.

ZAP FX-handlebars

- 28.6mm oversize handlebar with cross bar
- high strength 7075 T6 Ergal aluminum
- reinforced wall in the area of the bend and taper for maximum stability
- measurement scale for optimal positioning
- shot peened, anodized surface area for perfect, durable finish
- polished throttle side for minimal friction
- clutch side serrated for the best hold of grip
- with bar pad

ZAP-FX handlebars are used and developed by several off-road champions in the international motocross and enduro racing.



LENKER handlebars

MODEL	Ø	# REF	COLOR
FX CRF-STYLE	ø 28.6 mm	Z-8201 *	G S SI
FX SX-STYLE	ø 28.6 mm	Z-8202 *	G S SI
FX EX-STYLE	ø 28.6 mm	Z-8203 *	G S SI
FX RC-STYLE	ø 28.6 mm	Z-8204 *	BL S TI
FX RC-STYLE LOW	ø 28.6 mm	Z-8216 **	G S SI
FMX SX-STYLE	ø 28.6 mm	Z-8202X *	BL O S
FMX RC-STYLE	ø 28.6 mm	Z-8204X *	BL S TI
MX	ø 22.0 mm	Z-8212 *	BL G S TI

*Farbcode bitte unbedingt angeben!
*Color code is necessary!

**lieferbar ab 2016
**available from 2016!

Alle Lenker inklusive Lenkerpolster!
All handlebars with bar pad!



Z-8202X* FMX Lenker
28,6 mm oversized Lenker mit Strebe
28,6 mm oversized handlebar with cross bar



Z-8212* MX Lenker
22 mm mit Strebe
22 mm with cross bar

Z-8212* FX Lenker
28,6 mm oversized Lenker
28,6 mm oversized handlebar



ABMESSUNGEN *measurements*

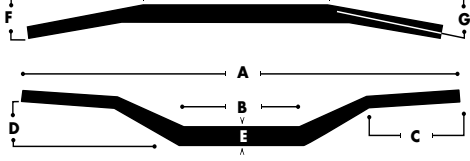

MODEL	# REF	A	B	C	D	E	F	G
CR-STYLE	Z-8201	800	210	195	109	28.6	66.2	14
SX-STYLE	Z-8202	810	183	185	112	28.6	65.0	10
EX-STYLE	Z-8203	810	183	185	122	28.6	65.0	10
RC-STYLE	Z-8204	810	206	210	102	28.6	77.5	13
RC-STYLE LOW	Z-8216	810	206	210	192	28.6	77.5	13
MX	Z-8212	810	183	185	112	22.0	65.0	10

LENKERPOLSTER

Hochwertige **Lenkerpolster** mit Vinyl-Cover und Schaumstoffkern in verschiedenen Farben und Ausführungen.

barpads

High quality **barpad** with vinyl-cover and foam core in various colours and designs.



MODEL	# REF			
	FMX-BARPAD	Z-8205	<input checked="" type="checkbox"/>	<input type="checkbox"/>
	FX-BARPAD	Z-8206	<input checked="" type="checkbox"/>	<input checked="" type="checkbox"/>
	FX-BARPAD	Z-8206#94S	<input checked="" type="checkbox"/>	



ZAP GABELBRÜCKEN

Neu überarbeitetes Design mit mehr Klemmfläche für die Gabelholme. Gefräst aus geschmiedetem Aluminium. Entwickelt und getestet von Topfahrern. In Verbindung mit unserer 3-teiligen Spezial-Lenkeraufnahme sind 16 verschiedene Lenker-Positionen möglich.



ZAP triple clamps

Redesigned with increased clamp surface for less fork flex. CNC from forged aluminum. Developed and tested by Team Honda Meyer In conjunction with our special 3 parts handlebar support are 16 different handlebar positions possible.

OBERE GABELBRÜCKEN + GABELBRÜCKENSÄTZE

top clamps + triple clamp sets

MODEL	NAME		COLOR	# REF
CR(F)	Factory Gabelbrücke oben / top triple clamp	CRF 250 10-, 450 09-		Z-C1013
RMZ	Factory Gabelbrücke oben / top triple clamp	RMZ 250 07-14, RMZ 450 05-14		Z-C4012
KXF	Factory Gabelbrücke oben / top triple clamp	KXF 250/450 13-		Z-C3018BL
	Factory Gabelbrücke oben / top triple clamp	KXF 250/450 13-		Z-C3018GR
	Factory Gabelbrücke oben / top triple clamp	KXF 250/450 13-		Z-C3018SI
	Factory Gabelbrückensatz / triple clamp set	KXF250/450 13- 21,5 mm offset		Z-C3111-21,5BL
	Factory Gabelbrückensatz / triple clamp set	KXF250/450 13- 21,5 mm offset		Z-C3111-21,5GR
	Factory Gabelbrückensatz / triple clamp set	KXF250/450 13- 21,5 mm offset		Z-C3111-21,5SI

T-BONE ANBAUKIT FÜR ZAP GABELBRÜCKEN

T-Bone mounting kit's for ZAP triple clamps

HÖHE	Ø	# REF	COLORS
35mm	Ø 26.8mm	Z-P21T	
40mm	Ø 26.8mm	Z-P22T	
45mm	Ø 26.8mm	Z-P23T	
55mm	Ø 26.8mm	Z-P24T	

Abstand = 100mm



ZAP T-BONE ANBAUKITS

- Umrüstung auf 28,6mm Lenker
- Ersetzung der Gummilagerung gegen starre Aluminiumbuchsen
- Verdrehen des Lenkers wird reduziert
- Verbiegen der Lenkeraufnahme wird reduziert

ZAP T-BONE mounting kits

- upgrade to 28.6 mm bars
- replacement of the rubber bearing against rigid aluminum bushings
- turning of handlebars is reduced
- bending the handlebar support is reduced



ERSATZ-ALUBUCHSEN replacement aluminium cones

MODEL	Ø	# REF	COLORS	# REF	COLOR
HONDA	ø 26.8mm	Z-P57TR		Z-PCR	
SUZUKI	ø 26.8mm	Z-P59TSI		Z-PRM	
KAWASAKI	450 nur -2011 ø 26.8mm	Z-P58TSI		Z-PKX	
	450 ab 2012 ø 26.8mm	Z-P58TSI2		Z-PKX2	

LENKERANBAUKIT UNIVERSAL mounting kit universal

MODEL	# REF	COLOR
ø 22.0mm 40.0mm hoch	Z-P12	
ø 28.6mm 35.0mm hoch	Z-P21	
ø 28.6mm 40.0mm hoch	Z-P22	
ø 28.6mm 45.0mm hoch	Z-P23	
ø 28.6mm 55.0mm hoch	Z-P24	

alle Bolzen ø 12mm



LENKERANBAUKIT

(40mm hoch) für original gummigelagerte Gabelbrücken (KXF, CRF, RMZ, u.a.) zum Umbau auf 28.6mm Oversize-Lenker. Anbausatz ist eloxiert, alle Schrauben inklusive.

MODEL	# REF	COLOR
ø 28.6mm 40.0mm hoch	Z-P32B	
ø 28.6mm 35.0mm hoch	Z-P32R	



mounting kit

Handlebar mounting kit (40mm high) for original rubber-supported crowns (KXF, CRF, RMZ, e.g.) for change into 28.6mm oversize levers. Mounting kit is anodized. All screws included.

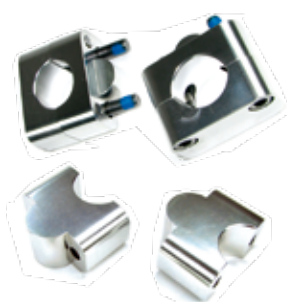

MODEL	NAME	# REF	COLOR
	Universal-Anbaukit zum Umrüsten universal mounting kit for change over ø 22 28.6mm	Z-8209	
KTM	Lenkererhöhung für KTM 35.0mm handlebar raiser kit for KTM 35.0mm	Z-8211	

ZAP
LEVERS

ZAP

ZAP

ZAP FLEXHEBEL + V2 = V2X ARMATUR

Die V2X Kupplungsarmatur ist eine Weiterentwicklung der V2-Armatur und vereint alle Eigenschaften der V2-Armatur mit den Vorteilen des Flexhebel-Systems zu einer fast unzerstörbaren Einheit.

- extra breite Hebelaufnahme an der Armatur
- funktionaler Staubschutz im Lieferumfang
- Schnellverstellung
- optionaler Heißstart
- optimierte Hebelübersetzung
- verstellbarer Hebelwinkel
- doppelt kugelgelagertes Gelenk
- gefertigt aus hochwertigen Materialien: Edelstahlschrauben, Chrom-Silikon-Federn, geschlossene Präzisionslager

ZAP flex levers + V2 = V2X clutch perch

The V2X clutch system is a development of the V2 clutch and has all the features of the V2 clutch with the advantages of the flexible lever system to a nearly unbreakable unit.

- extra wide handle socket on the clutch perch
- functional dust cover included
- quick adjustment
- optional hot start
- improved leverage
- adjustable lever angle
- double ball-bearing joint
- made from high quality materials: stainless steel screws, chrome-silicon springs, precision sealed bearings



ZAP KUPPLUNGSARMATUREN

- 1000-fach bewährtes Design
- geschmiedete Armatur und Lenkerklemmung mit Nylonbuchse
- inklusive Staubschutz und leichtgängiger Schnellverstellung

1 JAHR GARANTIE BEI BRUCH DER ARMATUR

ZAP clutch perches

- 1000 times approved design
- forged perch and fitting with nylon bushing
- includes dust cover and smooth quick adjustment

1 YEAR WARRANTY FOR BRAKE OF PERCH

V2X Armaturen

MODEL	# REF	COLOR
V2X-Armatur, blau / blue	Z-7300XB	
V2X-Armatur, rot / red	Z-7300XR	
V2X-Armatur, schwarz / black	Z-7300XS	
V2X-Ersatzhebel, blau / blue replacement lever	Z-7315XB	
V2X-Ersatzhebel, rot / red replacement lever	Z-7315XR	
V2X-Ersatzhebel, schwarz / black replacement lever	Z-7315XS	
Ersatz-Schnellverstellung mit Schraube, blau blue replacement adjuster with screw	Z-7314B	
Ersatz-Schnellverstellung mit Schraube, rot red replacement adjuster with screw	Z-7314R	
Ersatz-Schnellverstellung mit Schraube, schwarz black replacement adjuster with screw	Z-7314S	









HEISS-STARTHEBEL V2

hot start lever

MODEL	# REF	COLOR
Hot start lever V2 + V2X	Z-7311B	
Hot start lever V2 + V2X	Z-7311R	

V2 ARMATUREN

MODEL	# REF	COLOR
V2-Armatur, blau / blue	Z-7300B	
V2-Armatur, rot / red	Z-7300R	
V2-Armatur, schwarz / black	Z-7300S	
V2-Ersatzhebel / replacement lever	Z-7315	
V2-Ersatzhebel / replacement lever	Z-7315S	

- nahezu toleranzfreie Hebelaufnahme
- geschmiedeter, 3-fach kugelgelagerter Kupplungshebel

- nearly tolerance-free recording lever
- forged, 3-way ball bearing clutch lever



ZAP FLEX-HEBEL SERIE

Die kaltgeschmiedeten Hebelarme, CNC-gefrästen Gelenkstücke und der Klappmechanismus machen die Hebel fast unzerstörbar!

- gefertigt aus hochwertigen Materialien:
Edelstahlschrauben, Chrom-Silikon-Federn, geschlossenem Präzisionslager
- individuell einstellbare Hebelarme
- lasergraviertes ZAP-Logo



ZAP FLEX lever series

The cold forged lever arms, CNC machined parts and joints of the folding mechanism make the lever almost indestructible!

- made from high quality materials: stainless steel screws, chrome silicon springs, sealed precision bearings
- individually adjustable lever arms
- laser-engraved ZAP logo

FLEX BREMSHEBEL brake levers

MODEL	NAME	# REF			
HONDA	CR 92-, CRF 02-06	Z-11041F	B	R	
	CRF 07-	Z-11051F		R	S
SUZUKI	RM(Z) 04-	Z-31061F	B	R	S
KAWASAKI	KX(F) 00-12	Z-31061F	B	R	S
	KX(F) 13-	Z-41061F	B	R	S
YAMAHA	YZ(F) -07, YZF 250 -06	Z-31061F	B	R	S
	YZ(F) 08-, YZF 250 07-	Z-41061F	B	R	S
KTM	SX(F), EXC Brembo 05-13	Z-51051F	B	O	S
	SX(F), EXC Brembo 14-	Z-51051F	B	O	S
HUSQUARNA	TE, TC 125-510 14-	Z-51091F	B		S
SHERCO	SE(F) -14	Z-51051F	B		
	SE(F) 15-	Z-51091F	B		
GASGAS	alle 125-	Z-11041F	B	R	
BETA	RR alle 05-	Z-11041F	B	R	

Farbcode bitte unbedingt angeben! / Color is necessary!





HOT START

	# REF	COLOR
Hot start lever brakeside	Z-7200	B R

Farbcode bitte unbedingt angeben! / Color code is necessary!



FLEX KUPPLUNGSHABEL *clutch levers*

MODEL	NAME	# REF	COLOR
KTM	SX(F), EXC Magura hydr. 03-08 mit Einstellschraube / with adjustment screw	Z-51062F	O S
	SX(F), EXC Brembo 05-13	Z-51072F	B O S
	SX(F), EXC Magura 09-13	Z-51082F	B O S
HUSQVARNA	SX(F), EXC Brembo 14-	Z-51072F	B S
	SX(F), EXC Magura 14-	Z-51082F	B S
SHERCO	SE(F) -14	Z-51072F	B
GASGAS	AJP-Kupplung / AJP clutch	Z-71012X	B R
BETA	AJP-Kupplung / AJP clutch	Z-71012X	B R
TM	AJP-Kupplung / AJP clutch	Z-71012X	B R

Farbcode bitte unbedingt angeben! / Color code is necessary!



ZAP COMPETITION-HEBELSÄTZE

Die Hebel für preisbewusste Fahrer, die auf die Vorteile eines Klapphebels nicht verzichten wollen! Farbige eloxiert aus CNC-gefrästem Aluminium mit lasergraviertem ZAP-Schriftzug, kann meist mit originalem Staubschutz verwendet werden.

Top Preis- Leistungsverhältnis!

MODEL	NAME	# REF	COLOR
HONDA	CRF 250/450 04- 06	Z-11001R	■
	CRF 250/450 04- 06	Z-11001S	■
	CRF 250/450 07	Z-11002R	■
	CRF 250/450 07	Z-11002S	■
SUZUKI	RMZ 250 07-, 450 05-	Z-21001R	■
	RMZ 250 07-, 450 05-	Z-21001S	■
KAWASAKI	KXF 250/450 05-12	Z-31001B	■
	KXF 250/450 05-12	Z-31001S	■
	KXF 250/450 13-	Z-31002B	■
	KXF 250/450 13-	Z-31002S	■
YAMAHA	YZF 250/450 09-	Z-41001B	■
	YZF 250/450 09-	Z-41001S	■
KTM	BREMBO 06-/BREMBO 05-13	Z-51001B	■
	BREMBO 06-/BREMBO 05-13	Z-51001O	■
	MAGURA 09-/BREMBO 05-13	Z-51002B	■
	MAGURA 09-/BREMBO 05-13	Z-51002O	■
KTM/HSQ	BREMBO 06-/BREMBO 14-	Z-51003B	■
	BREMBO 06-/BREMBO 14-	Z-51003O	■
	MAGURA 09-/BREMBO 14-	Z-51004B	■
	MAGURA 09-/BREMBO 14-	Z-51004O	■
BETA	RR alle, Brembo/Nissin	Z-71001B	■
	RR alle, Brembo/Nissin	Z-71001R	■

ZAP COMPETITION levers

The lever for price-conscious riders who don't like to miss the benefits of a folding lever! CNC-machined and anodized with laser engraved ZAP-logo.

Great price-performance ratio!



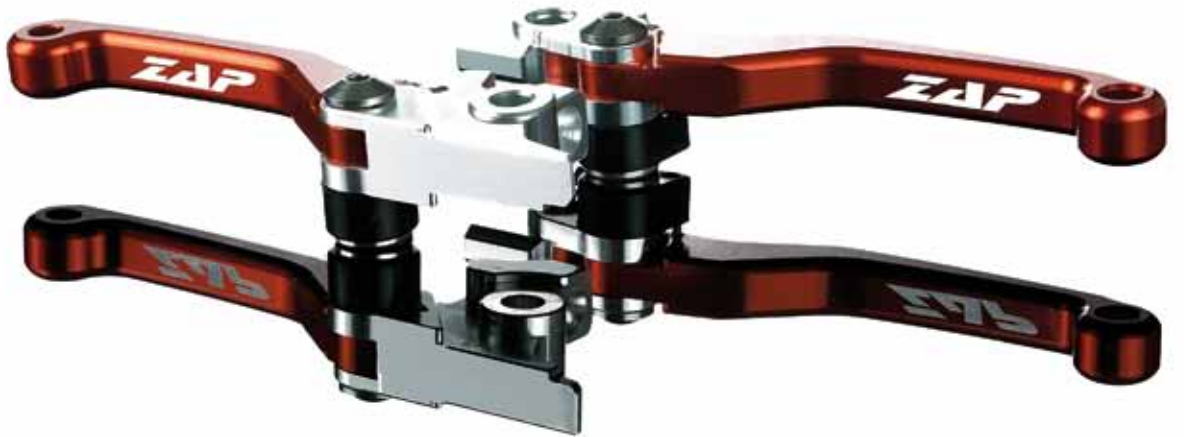



KUPPLUNGHEBEL + ARMATUREN *clutch levers + armatures*

MODEL	NAME	OEM	FACTORY	ARMATUR
HONDA	CR 125-500, 83-03	Z-11042	Z-11042G	Z-1006
	CR 125-250, 04-07	Z-11052	Z-11052G	Z-1007
	CRF 250-450, 02-03	Z-11042	Z-11042G	-
	CRF 250 04-09, 450 04-08	Z-11052	Z-11052G	S Z-1009
	CRF 250 10-, 450 09-	Z-11052	Z-11052G	S Z-1007
SUZUKI	RM 125-250, 90-07	Z-21042	Z-21042G	Z-2006
	RM 125-250, 04-	Z-21042	Z-21042G	Z-2007
	RMZ 250 04-, 450 05-	Z-31042	Z-31042G	-
KAWASAKI	KX 125-500, 92-03	Z-31042	Z-31042G	Z-3006
	KXF 250 05-10, 450 06-08	Z-41052	Z-41052G	S Z-3007
	KXF 450 09- / 250 -11	Z-41052	Z-41052G	S Z-4007
YAMAHA	YZ 125-400, 89-99	Z-21042	Z-21042G	Z-2006
	YZ 125-450, 00-08	Z-21052	Z-21052G	Z-4007
	YZ 125-450, 09-	Z-41082	Z-41082G	S Z-4009
	WR 250-450, 03-04	Z-41062	-	-
	WR 250-450, 05-	Z-41072	-	-
KTM	LC4 (Seilzug)	Z-51032	-	-
	2Takt 93-97 (Seilzug)	Z-51042	-	-
	125-525 EXC/SX 98-02	Z-51052	Z-51052G*	-
	125-525 EXC/SX 03-08 (m. Magura)	Z-51062	Z-51062GX*	-
	125-525 EXC/SX 03-08 (m. Magura) lang /long	Z-51062L	Z-51062GLX*	-
	125-525 EXC/SX 05- (m. Brembo)	Z-51072	Z-51072G	S -
	125-525 EXC/SX 09- (m. Magura)	-	Z-51082G	S -
HUSQUARNA	2T 94-13	Z-51042	-	-
	4T 92-00	Z-51032	-	-
	4T 01-02	Z-51052	Z-51052G	-
	4T 03-09	Z-51062	Z-51062GX	-
	4T 10- (m. Brembo)	Z-51072	Z-51072G	S -
SHERCO	SE(F)	Z-51072	Z-51072G	S -
SONSTIGE	GASGAS, TM, BETA für AJP-Armatur	-	Z-71012G	-

*inklusive Einstellschraube / including adjustable screw



Z-1006



Z-1007



Z-1009



Z-2006



Z-2007



Z-3006



Z-3007



Z-4007



Z-4009

	# REF
 Stellschraube für Hebel passend an Magura-Hydraulikkupplungen adjection screw for lever to fit Magura hydraulic clutches	Z-51063

KUPPLUNGS- UND BREMSHEBEL

Die kaltgeschmiedeten ZAP Factory-Hebel sind 500% robuster als herkömmliche Aluminium-Druckguss-Ausführungen, oder erhältlich als OEM-Style in Standard-Druckguss-Ausführung als preiswerter Originalersatz.

clutch and brake levers

The cold-forged ZAP factory-arms are 500% stronger than conventional aluminum die-cast models, or to order as an OEM style standard in cast design, as affordable original replacement.

FACTORY STYLE

Modelle mit **S** auch als „black edition“ erhältlich kaltgeschmiedeter Hebel

Ein Muss für den Racing-Einsatz!



OEM STYLE

Hebel in Standard-Gussausführung

BREMSHEBEL brake levers

MODEL	NAME	OEM	FACTORY
HONDA	CR 92-, CRF 250/450 04-06	Z-11041	Z-11041G
	CRF 250/450 07-	Z-11051	Z-11051G S
SUZUKI	RM 85 96-01, RM 125/250 96-03	Z-11041	Z-11041G
	RM 80, RM 125-250 87-95	Z-21041	-
	RM 125-250 04-, RMZ 250 04-/450 05-	Z-31061	Z-31061G S
KAWASAKI	KX 125-500 93-95	Z-11041	Z-11041G
	KX 125-500 97-99	Z-31051	-
	KXF 125-500 00-12	Z-31061	Z-31061G S
	KXF 250- 450 13-	Z-41061	Z-41061G S
YAMAHA	YZ 125-450 01-07	Z-31061	Z-31061G S
	YZ 125-400 96-00	Z-41051	-
	YZF 250 07-, 125-450 08-	Z-41061	Z-41061G S
KTM	Brembo alle 93-99	Z-51041	-
	Brembo alle 00-04	Z-51051	Z-51051G
	SX 85 04-11	-	Z-51061G
	SX/EXC 125-660 alle 05-13	Z-51071	Z-51071G S
	SX 85 12-, Freeride	-	Z-51081G
	SX/ EXC 125- 660 14-	Z-51091	Z-51091G S
HUSQUARNA	alle -99	Z-51041	-
	4T alle 00-	Z-51051	Z-51051G
	TC 85 15-		Z-51081G
	alle -99	Z-51041	
	alle 00-13	Z-51051	Z-51051G
125-510 14-	Z-51091	Z-51091G S	
SHERCO	SE(F) -14	Z-51071	Z-51071G S
	SE(F) 15-	Z-51091	Z-51091G S
SONSTIGE	GASGAS / BETA alle	Z-11041	Z-11041G



ZAP GRIFFGUMMIS grips

Hochwertiger 2-Komponenten MX-Griffgummi in Halbwellenform.

MX grips ZAP DUAL













High quality 2-component MX-Grips in half waffle shape.



Z-8096-99

Z-8028S

GRIFFGUMMI grips

MODEL	# REF	COLORS
MX 2	Z-8023G	
	Z-8023S	
PYRAMID	Z-8028S	 
Dual	Z-8096	 
	Z-8097	 
	Z-8098	 
	Z-8099	 









Z-8023S



ZAP GASGRIFFHÜLSEN

- CNC gefrästes Aluminium
- leichtgängig und stabil
- kugelgelagert am Lenkerende
- teflongelagert am Anfang der Hülse
- keine regelmäßige Schmierung notwendig

MODEL	# REF	COLORS
CRF	Z-1001LR	
2-Takt KTM/Honda CR	Z-2001LO	
2-Takt KTM/Honda CR	Z-2001L	
YZF, KXF, RMZ	Z-4001L	
2-Takt Yamaha/Suzuki	Z-4002LB	
KTM 4-Takt	Z-5003LO	
KTM 4-Takt	Z-5003L	

ZAP throttle tubes

- CNC milled aluminum
- ball bearings on the handlebar
- teflon bearings at the top of the sleeve
- extremely smooth and stable
- no periodic lubrication required



GASGRIFFE throttles

MODEL	# REF
Honda CRF 250/450	Z-8054
KXF 250/450 ua.	Z-8056
Yamaha 2-Takt /+ Uni	Z-8053
KTM 4-Takt universal	Z-8051
Gummischutz für Gasgriff rubber protection for throttle	Z-8055

Z-8055



Z-8056



Z-8054



Z-8051



Donuts

	# REF
2 Neopren Donuts 5mm	Z-8029



Z-8053



ZAP FUSSBREMSHEBEL

- Hebelarm aus kaltgeschmiedetem Aluminium
- 2-farbiges Design
- gefräster Tritt für maximale Stabilität und mit super griffigen Stahlspitzen
- Trittläche ist in 2 verschiedenen Positionen verstellbar
- robust und passgenau

rear brake pedal

- lever arm from cold forged aluminum
- 2-color-design
- CNC machined tip for maximum strength and with super-grip steel inserts
- tip is adjustable in two different positions
- strong with perfect fit



FUSSBREMSHEBEL rear brake pedal

MODEL	NAME	# REF
Honda	CRF 250 10-, CRF 450 09-	Z-14002 R
Suzuki	RMZ 250 12-, RMZ 450 08-	Z-24001 R
Kawasaki	KXF 250/450 06-	Z-34001 B R G
Yamaha	YZF 250/450 14- YZ 125/250 05-	Z-44001 B Z-44002 B S
KTM	SX(F)/EXC 125-525 08-, außer 350	Z-54001 O
Husqvarna	TE, TC 125-510 14-, außer 350	Z-54001 B

Farbcode bitte unbedingt angeben! / Color code is necessary!

ZAP SCHALTHEBEL

- extrem robust aus geschmiedetem Aluminium
- klappbares, bewährtes Schaltgelenk
- zweifarbig eloxiert
- passgenau, in Original-Form



SCHALTHEBEL shift levers

MODEL	NAME	# REF	COLOR
HONDA	CR 80/85	Z-12002	R
	CRF 250 02-	Z-12003	R
	CRF 450 02-	Z-12004	R
	CR 125 90-07	Z-12005	R
	CR 250 02-07	Z-12006	R
	CRF 150 07-	Z-12008	R
SUZUKI	RM 120 90-	Z-22001	R
	RM 80/85	Z-22002	R
	RM 250 88-	Z-22003	R
	RMZ 450 05-07	Z-22004	R
	RMZ 250 07-	Z-22005	R
	RMZ 450 08-	Z-22006	R
KAWASAKI	KX 80/85 91-	Z-32002	R
	KXF 250, RMZ 250 04-05	Z-32003	R
	KX 65/125/250	Z-32004	R
	KXF 450 06-08	Z-32006	R
	KXF 250 09-	Z-32007	R G
	KXF 450 09-15	Z-32008	R
KXF 450 2016-	Z-32009G	R G	
YAMAHA	YZ 250 96-16	Z-42003	B
	YZ 250F -05	Z-42004	B
	YZF 250/450 06-13	Z-42006	B
	YZF 250/450 14-	Z-42007	B
KTM	2Takt 08-, SX 250F 06-, EXC 250F 07-, SX/EXC 350F 11-	Z-52001	O
	4Takt SX/EXC 00-	Z-52002	O R
	LC4	Z-52003	O
	SX 85	Z-52004	O
HUSQUARNA	alle 2Takt ab 125 ccm 14-	Z-52001	B
	alle 4Takt 14-	Z-52002	B
	TC 85 2015-	Z-52004	B
GASGAS	alle EC/MC 98-	Z-72001	R
BETA	RR alle 05-09	Z-52002	R
	RR alle 10-	Z-52002	R
SHERCO	SE 2T 2014-	Z-72003	B
	SEF 4T 2015-	Z-72004 *	B

ZAP shift levers

- extremely rugged forged aluminum
- flexible, proven gearshift
- two-tone anodized
- perfect fit, in original form

* lieferbar ab Sommer 2016
* available from summer 2016



ZAP FUSSRASTEN

- ZAP Aluminium E-PEG Fußrasten
- neues ergonomisches Design
Resultat aus über 10 Jahren Erfahrung mit Aluminium Fußrasten
- verbessertes Schalten und Motorradkontrolle
- 30% weniger Verschleiß an der Stiefelsohle, - gegenüber dem X-Design
- 2 verschiedene Spike Einsätze in Lieferumfang enthalten
- CNC gefräst aus besten 7075 Aluminium
- extra breit für maximalen Halt
- geschütztes Design!



ZAP footpegs

- new ergonomic design, as a result of 10 years experience with aluminium footpegs
- E-Design improves shifting and high speed bike control
- 30% less boot wear compair to X-Design
- 2 different spike designs including, wild and mild
- CNC machined from best 7075 aluminium
- extra wide gesign for maximum grip and minimum weight
- registred design!

1

USED BY SX CUP CHAMPIONS



ZAP ALUMINIUM E-PEG FUSSRASTEN

footpegs



MODEL	NAME	# REF	COLOR
HONDA	CR/CRF 02-	Z-EP101RO SI S	R SI S
KAWASAKI	KXF 250 06- / 450 07-	Z-EP301GR R SI	R SI G
	KX 85	Z-EP381GR SI	SI G
YAMAHA	YZ(F)	Z-EP401	R SI B
KTM	EXC, SX(F) -2015	Z-EP401*	R SI B O
	SX(F) 125-450, 2016-	Z-EP502*	SI B O
HUSQVARNA	TE, FE, TC, FC -2015	Z-EP401*	R SI B
	FC/TC 125- ab 2016	Z-EP502	SI B
GASGAS	Gas Gas	Z-EP401*	R SI B
SHERCO	SE, SE(F)	Z-EP401*	R SI B

* bei diesen Modellen kann die Fußraste um ca. 1cm in der Höhe verstellt werden
the footpeg can be adjusted by about 1cm in height, in these models

Farbcode bitte unbedingt angeben!
Color code is necessary!

	# REF
Fußrastenfeder / footpeg springs Yamaha f. KTM/HB/HSQ	Z-FPFY
Fußrastengewinde-Einsatzkit footpeg thread operation kit	Z-FPRP





ZAP OVERSIZE - BREMSSCHEIBEN SequenZe

ZAP Technix SequenZe Oversize-Bremsscheiben wurden bei zahlreichen Enduro-WM-Läufen getestet und sind für alle gängigen Modelle verfügbar.

Alle SequenZe Oversize-Bremsscheiben bestehen aus einer schwimmend gelagerten, diamantgeschliffenen Bremsfläche (Edelstahl) und einem Innenring aus hochwertigem Aluminium (T6 7075). So ist es möglich die Bremsleistung einer 270 mm großen Bremsscheibe mit minimalem Gewicht zu vereinen.

Durch den speziellen SequenZe-Schliff der Bremsfläche wird außerdem die Selbstreinigung und Kühlung der Bremsfläche optimiert.

ZAP oversize brake discs SequenZe

Zap Technix SequenZe oversize-discs were tested in the Enduro World Championship and are available for all current models.

All SequenZe oversize-discs consists of a floating, diamond-ground braking surface (stainless steel) and an inner ring of high-grade aluminum (T6 7075). So it is possible to unite the braking power of the 270mm brake disc with minimum weight.

The special SequenZe cut of the braking surface also optimizes the self-cleaning and cooling of the braking surface.



270mm BREMSSCHEIBE SEQUENZE INKL. ADAPTER

270mm brake disc sequenze incl. adapter

ERSATZ- BREMSSCHEIBE

brake disc
replacement

MODEL	# REF	# REF	# REF
HONDA	CR(F) 89-, CRF 02- 270mm incl. adapter	Z-B10270R	Z-BD10270
SUZUKI	RM(Z) 250 07-, RMZ 450 05- 270 mm incl. adapter	Z-B20270	Z-BD20270
KAWASAKI	KX(F) 125/250 06-, KXF 250/450 06- 270 mm incl. adapter	Z-B30270	Z-BD30270
YAMAHA	YZ(F) 125/250 08-, YZF 250 07-, YZF 450 08- 270 mm incl. adapter	Z-B41270	Z-BD41270
KTM	SX/SXF 09-, EXC/EXC-F 10- 270 mm incl. adapter	Z-B50270	Z-BD50270

BREMSSCHEIBE SEQUENZE-ORIGINAL GRÖSSE

brake disc sequenze OEM size

MODEL	# REF		# REF
HONDA	CR(F) 95-14	vorn	Z-B10240F
	CR(F)125-450 02-	hinten	Z-B10240R
	CR(F) 2015- 260mm	vorn	Z-B10260F
SUZUKI	Suzuki RMZ 07-	vorn	Z-B20250F
	RMZ450/05-, 250/07-	hinten	Z-B20255R
KAWASAKI	KX(F) 03-	hinten	Z-B30208R
	KXF 06- 14	vorn	Z-B30250F
	KXF 2015- 270mm	vorn	Z-B30270F
YAMAHA	YZ(F) 02-	hinten	Z-B40190R
	YZ(F) 01-15	vorn	Z-B41250F
	YZ(F) 2016- 270mm	vorn	Z-B41270F
KTM	KTM SX/SXF/EXC/EXC-F 89-	hinten	Z-B50220R
	KTM 94-	vorn	Z-B50260F



EINSTELLER HINTERRAD-BREMSE

brake adjuster

MODEL	# REF	COLORS
CR(F) 02-	Z-8117	R
RM(Z) M6	Z-8115	B R
KX(F) M8	Z-8116	B R
YZ(F) M6	Z-8115	B R



BREMSBELAGBOLZEN brake pin

MODEL	# REF
Brembo hinten mit Splint / rear with clips	Z-8013
Nissin vorn (kurz) / front (short)	Z-8010
Nissin hinten (lang) / rear (long)	Z-8011
Honda CRF hinten / rear	Z-8039



ZAP BODENPLATTEN MOTORSCHUTZ

- durchdachtes Design, optimale Passform, Löcher zur Belüftung
- effektiver Schutz für Rahmen und Motor bei Motocross und Enduro
- inklusive allem Anbaumaterial

ZAP GLIDE PLATES

- approved design, perfect fit, holes for ventilation
- effective protection for the frame and engine
- includes all mounting hardware

MODEL	NAME	GLIDE PLATE	ENDURO GLIDE PLATE
HONDA	PE-HD MX CRF 250 14-	Z-GP10250-14PEHD	
	PE-HD MX CRF 450 09-	Z-GP10450PEHD	
SUZUKI	PE-HD MX RMZ 250 15-	Z-GP20250-15PEHD	
	PE-HD MX RMZ 250 '10-14	Z-GP20250PEHD	
	PE-HD MX RMZ 450 '08-	Z-GP20450PEHD	
KAWASAKI	PE-HD MX KXF 250 10-	Z-GP30250PEHD	
	PE-HD MX KXF 450 12-15	Z-GP30450-12PEHD	
	PE-HD MX KXF 450 16-	Z-GP30450-16PEHD	
YAMAHA	PE-HD MX YZF 250 14-	Z-GP40250PEHD	
	PE-HD MX YZF 450 14-	Z-GP40450PEHD	
KTM	Aluminium ENDURO KTM 2t 250/300 07-011		Z-EGP52250
	Aluminium ENDURO KTM 2t EXC 250/300 2012-		Z-EGP52250-12
	Aluminium ENDURO KTM 2t 250/300 2014-		Z-EGP52250-14PEHD
	Aluminium ENDURO KTM 4t EXCF 250 08-11		Z-EGP54250
	Aluminium ENDURO KTM 4t EXCF 250 12-14		Z-EGP54250-12
	Aluminium ENDURO KTM 4t EXCF 350 12-14		Z-EGP54350-12
	PE-HD ENDURO KTM 4t EXCF 350 12-		Z-EGP54350-12PEHD
	Aluminium ENDURO KTM 4t EXCF 250/350 15-		Z-EGP54350-15
	Aluminium ENDURO KTM 4t EXCF 450/530 08-11		Z-EGP54450
	Aluminium ENDURO KTM 4t EXC 450/500 12-		Z-EGP54450-12
	PE-HD ENDURO KTM 4t EXCF 450 12-		Z-EGP54450-12PEHD
	PE-HD MX KTM SXF 250 13-14	Z-GP54250-11PEHD	
	Aluminium MX KTM SXF 250 13-14	Z-GP54250-13	
	Aluminium MX KTM SXF 250 2015-	Z-GP54250-15	
	Aluminium MX KTM 4t SXF 350 11-14	Z-GP54350	
	PE-HD MX KTM 4t SXF 350 11-14	Z-GP54350PEHD	
	Aluminium MX KTM 4t SXF 450 13-14	Z-GP54450-13	
	PE-HD MX KTM 4t SXF 450 13-14	Z-GP54450-13PEHD	
GASGAS	Aluminium ENDURO GasGas 2t 200-300 12-13		Z-EGP62250-12
	Aluminium ENDURO GasGas 2t 200-300 12-		Z-EGP62250-12PEHD
	Aluminium ENDURO GasGas 2t 200-300 14-		Z-EGP62250-14
HUSQVARNA	Aluminium Husqvarna FE-FC 2014/15	Z-GP54250-15	
BETA	Aluminium ENDURO Beta RR RR 2T 250/300 13-		Z-EGP110300-13
	PE-HD ENDURO Beta RR 2T 250/300 13-		Z-EGP110300-13PEHD
	Aluminium ENDURO Beta RR 4T 350-450-520 12-		Z-EGP110450-12

SCHAUMBLOCK foam block

	# REF
universal 30x14x4 cm	Z-FOAMBLK



ALUMINIUM MOTORSCHUTZ

- aus hochwertigem Aluminium 4mm stark
- Enduro Bodenplatte mit seitlichem Schutz
- eingravierter ZAP Schriftzug
- inklusive Moosgummiband und Schaumblock

made of aluminium

- manufactured of high quality aluminum 4mm thick
- enduro glide plate with side motor protection
- engraved ZAP sign
- Includes all mounting hardware, foam rubber strip and foam block

PE-HD KUNSTSTOFF MOTORSCHUTZ

- aus hochwertigem PEHD (Polyethylen)
- 6mm stark, sehr beständig und leicht
- inklusive Schaumblock

made of high-grade PEHD (Polyethylene)

- made from high-grade PEHD (polyethylene) 6mm thick
- very durable and lightweight
- Includes foam block



ZAP KÜHLER

KÜHLER FLOW MASTER

- ZAP TechniX Flow-Master Kühler
- hergestellt aus hochfestem Aluminium
 - 40 mm tief mit 2 Lamellenreihen für doppelte Kühlkapazität
 - deutlich stabiler als OEM Kühler
 - inkl. 1,3 bar Kühlerdeckel
 - sehr gutes Preisleistungs-Verhältnis!

ZAP radiator

- ZAP TechniX flow master radiator
- heavy duty aluminum design
- 2 row 40mm core for ingreased cooling
- cores welded in vacuum brazing furnace and tanks welded by TIG no epoxy !
- including 1,3 bar radiator cap

RACING-KÜHLERDECKEL 1,6 Bar

Racing-radiator
cover 1,6 Bar



Z-FM0016

	# REF
Kühlerdeckel	Z-FM0016

MODEL	NAME	# REF
CR(F)	CRF 450/ 09-12 links	Z-FM1001A
	CRF 450/ 09-12 rechts	Z-FM1001B
	CRF 450/ 05-08 links	Z-FM1002A
	CRF 450/ 05-08 rechts	Z-FM1002B
	CRF-X 450/ 05-+++ links	Z-FM1003A
	CRF-X 450/ 05-+++ rechts	Z-FM1003B
	CRF 250/ 04- 09 links	Z-FM1008A
	CRF 250/ 05-08, CRF 250X 04- 13 rechts	Z-FM1008B
	CRF 250/ 10- 13 links	Z-FM1019A
	CRF 250/ 10- 13 rechts	Z-FM1019B
	CRF 450/ 13- 14 links	Z-FM1038A
	CRF 450/ 13- 14 rechts	Z-FM1038B
	CRF 250 14- 15 links	Z-FM1046A
	CRF 250 14- 15 rechts	Z-FM1046B
	CRF 450/ 15- links	Z-FM1058A
	CRF 450/ 15- rechts	Z-FM1058B
CRF 250 16 links	Z-FM1065A	
CRF 250 16 rechts	Z-FM1065B	
RM(Z)	RMZ 450 08- 10 links	Z-FM2011A
	RMZ 450 08- 10 rechts	Z-FM2011B
	RMZ 250 10- 12 links	Z-FM2012A
	RMZ 250 10- 12 rechts	Z-FM2012B
	RMZ 250 13- links	Z-FM2028A
RMZ 250 13- rechts	Z-FM2028B	
KXF(F)	KXF 250 09- 10 links	Z-FM3005A
	KXF 250 09- 10 rechts	Z-FM3005B
	KXF 450 10- 11 links	Z-FM3012A
	KXF 450 10- 11 rechts	Z-FM3012B
	KXF 250 11- links	Z-FM3017A
	KXF 250 11- rechts	Z-FM3017B
	KXF 450 12- links	Z-FM3020A
	KXF 450 12- rechts	Z-FM3020B





MODEL	NAME	#REF
YZ(F)	YZ450F 07- 09, WR450F 07- 12 links	Z-FM4001A
	YZ450F 07- 09, WR450F 07- 12 rechts	Z-FM4001B
	YZ250F 07- 09 links	Z-FM4008A
	YZ250F 07- 09 rechts	Z-FM4008B
	YZ450F 2010- 13 links	Z-FM4013A
	YZ450F 2010- 13 rechts	Z-FM4013B
	YZ250 2002- links	Z-FM4015A
	YZ250 2002 rechts	Z-FM4015B
	YZ250F 10- 13 links	Z-FM4022A
	YZ250F 10- 14 rechts	Z-FM4022B
	YZF 250/450 2014 links	Z-FM4046A
	YZF 250/450 2014- rechts	Z-FM4046B
KTM	KTM 2T SX 125/250 07-, EXC 125/250/300 08 links	Z-FM5005A
	KTM 2T SX 125/250 07-, EXC 125/250/300 08 rechts	Z-FM5005B
	KTM 4T EXC-F 250/350/450/530 08 links	Z-FM5006A
	KTM 4T EXC-F 250/350/450/530 08- rechts	Z-FM5006B
	KTM 2T SX 125/250 98- 06, EXC 125/250/300 98- 07 links	Z-FM5008A
	KTM 2T 125/250 98- 06, EXC 125/250/300 98- 07 rechts	Z-FM5008B
SHERCO	Sherco 2T SE 250/300 14- links	Z-FM8001A
	Sherco 2T SE 250/300 14- rechts	Z-FM8001B
	Sherco 4T SEF 250/300 13- links	Z-FM8002A
	Sherco 4T SEF 250/300 13- rechts	Z-FM8002B
BETA	Beta RR250/300 2T 2013- 15 links	Z-FMBT001A
	Beta RR250/300 2T 2013- 15 rechts	Z-FMBT001B
	Beta RR350-520 4T 2011- 15 links	Z-FMBT002A
	Beta RR350-520 4T 2011- 15 rechts	Z-FMBT002B
GASGAS	GasGas MX/SH/EC 200/250/300 07-13 links	Z-FMBT002B
	GasGas MX/SH/EC 200/250/300 07-13 rechts	Z-FMGG003B

Weitere Modelle finden Sie
auf unserer Website
www.zap-technix.com



ZUSATZKÜHLER

- universal passend
- senkt die Kühlwassertemperatur
- leichte Montage zwischen Kühler und Wasserpumpe
- inklusive Schellen



cooler

- fits universal
- reduces the cooling water temperature
- easy installation between the radiator and water pump
- included clamps



	# REF	COLORS
Zusatzkühler universal Durchmesser 35mm , Gesamtlänge 120mm , Durchlauf 18mm Cooler universal: Diameter 35mm , Overall length 120mm , Pass 18mm	Z-8137	
Zusatzkühler universal QUAD Durchmesser 38mm , Gesamtlänge 100mm , Durchlauf 18mm Cooler universal QUAD: diameter 38mm , overall length 100mm , pass 18mm	Z-Q8404R	

SILIKON-KÜHLERSCHLÄUCHE

- verstärkt durch Polyesterfasern
- erhöhte Wandungsstärke
- maximaler Druck: bis 6 bar
- maximale Temperatur: 215 °C
- factory Look

silicone hoses

- reinforced with polyester fibers
- increased wall thickness
- maximum pressure: up to 6 bar
- maximum temperature: 215°C
- factory look

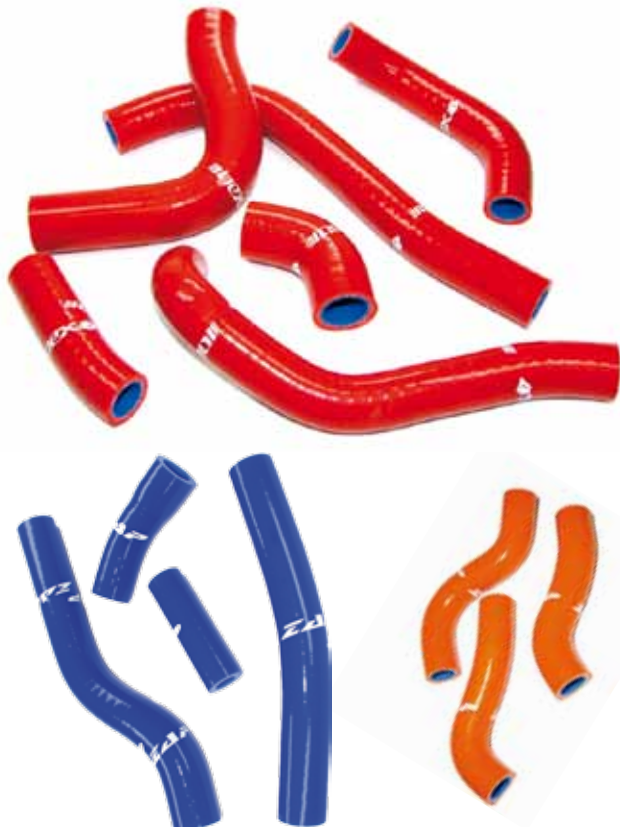

MODEL	NAME	# REF	COLORS
HONDA	CRF 250 10-13	SH-HD521R	
	CRF 250 14-	SH-HD527BL	
	CRF 450 09- 12	SH-HD517R	
	CRF 450 13-14 Y-Kit	SH-HD526-1BL	
KTM	KTM EXC 250/ 300 2T 08-	SH-KT5110	
	KTM SX 85 2013-	SH-KT0820	
	KTM SXF 350 11-	SH-KT512-10	
	KTM SXF 450 13-	SH-KT081	
	KTM SXF/EXCF 250 08-	SH-KT5040	
	KTM SXF 450 08-09	SH-KT5030	
KAWASAKI	KXF 250 09- Y-Kit	SH-KW516-1BL	
	KXF 450 09-15 Y-Kit	SH-KW517-1BL	
	KXF 450 09-15	SH-KW517BL	
SUZUKI	RMZ 250 07- 09	SH-SU510B	
	RMZ 250 07-09	SH-SU510R	
	RMZ 250 11-12	SH-SU523B	
	RMZ 450 08-	SH-SU509B	
	RMZ 450 08-	SH-SU509R	
YAMAHA	YZ 125 05-	SH-YA006BL	
	YZ 250 05-	SH-YA005BL	
	YZF250 10-13	SH-YA521B	
	YZF 250 14-	SH-YA531BL	
	YZF450 03-09	SH-YA511R	
	YZF 450 14-	SH-YA529BL	
HUSQVARNA	Husqvarna TE 250/ 300 2T 14-	SH-HQ053	
	Husqvarna TC 85 2013-	SH-HQ082	

ZAP KÜHLERSCHUTZ

- aus stabilem 4mm starken Aluminium hergestellt
- bieten ausgezeichneten Schutz für die empfindlichen Kühler

Präzise lasergeschnittene Teile garantieren problemlose und exakte Montage an vorhandenen Anschraubpunkten.

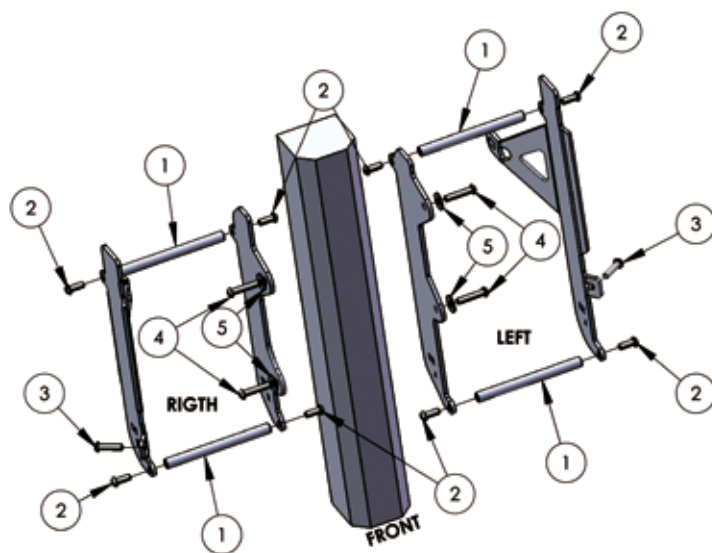

ZAP radiator guards

- made of sturdy 4mm thick aluminum
- thus offer excellent protection for the vulnerable radiator
- precise laser cut parts for a smooth and exact installation

MODEL	NAME	# REF
HONDA	CRF 250 '10-13	Z-RG10250
	CRF 250 14-	Z-RG10250-14
	CRF 450 09-12	Z-RG10450
	CRF 450 2013-2014	Z-RG10450-13
SUZUKI	RMZ/RMX 450 '10-	Z-RG20450
	RMZ 250 '10-	Z-RG20250
KAWASAKI	KXF 250 '10-	Z-RG30250
	KXF 450 2012- 15	Z-RG30450-12
	KXF 450 2016	Z-RG30450-16
YAMAHA	YZF 250/450 14-	Z-RG40450-14
	YZF 250 '10-13	Z-RG40250
	YZF 450 '10-13	Z-RG40450
	WR 250F 15-	Z-RG40450-15
KTM	KTM EXC alle 08-/SX(F) alle 07-15	Z-RG50250/450
	KTM SXF 2016	Z-RG50250/450-16
SHERCO	SHERCO SEF 250/300 2T 12-	Z-RG72300
	SHERCO SEF 250/300 4T 12-	Z-RG74300
BETA	Beta RR 250/300 13-	Z-RG110300
	Beta RR 350-520 05-	Z-RG110450
GASGAS	GAS GAS alle 2T 125-300 07-	Z-RG60250





LUFTFILTER FEUERFEST

- 3-lagig für beste Filterung für maximale Leistung
- leicht zu positionieren
- Innenseite aus feuerfestem Schaum – für 4-Takt Bikes

airfilter fireresistant

- triple layer for optimum filtration and maximum performance
- easy to position
- lined with fireproof foam - for 4-stroke bikes

MODEL	NAME	# REF
HONDA	CRF 250 10-13/450 09-	Z-L5129
	CRF 250 14-/450 13-	Z-L5132
SUZUKI	RM 04-/RMZ 05-	Z-L5330
KAWASAKI	KXF 250 06- 16, 450 06- 15	Z-L5228
	Kawasaki KXF 450 2016-	Z-L5235
YAMAHA	YZ(F) 98-	Z-L5330
	YZF 250/450 2014-	Z-L5367
KTM	KTM SX(F) 2011- 15, EXC 2012-	Z-L5822
	KTM SX 2016-, Husky TC 2016-	Z-L5823
BETA	Beta RR 250/300/350/450/525 alle 13-	Z-L51507



LUFTFILTER-ÜBERZUG

- 3er-Pack
- auswaschbar, somit wiederverwendbar
- universal passend
- schützt Filter und Motor vor Staub und Sand

air filter cover

- 3 pieces of pack
- washable reusable
- easy to position
- protects filter and engine from dust and sand

MODEL	# REF
Universal	Z-FS

ZAP LUFTFILTER

- 2-lagig für maximale Leistung
- leicht zu positionieren

ZAP airfilter

- two layer for maximum performance
- easy to position



MODEL	NAME	# REF
HONDA	CR 80/85 86-	Z-L0102
	CR 125/250(97-)	Z-L0110
	CRF 250 03-09/450 03-08	Z-L0125
	CRF 250 10-13/450 09-12	Z-L0129
	CRF250 14-/450 13-	Z-L0132
	CRF 450 2002	Z-L0123
SUZUKI	RM 80/85 86-	Z-L0402
	RM 125 02-03/ 250 02-03	Z-L0417
	RMZ 250 04-06	Z-L0426
	RM 04-/RMZ 05-	Z-L0330/0423
	LTZ/KFX 400 Quad	Z-L0425Q
	LTR 450 Quad	Z-L0432Q
KAWASAKI	KX 80/85 91-	Z-L0216
	KX 125/250 94-	Z-L0220
	KXF 250 06- 16, 450 06- 15	Z-L0228
	KFX 450 Quad	Z-L0231Q
	KXF 450 2016-	Z-L0235
	KXF 04-05	Z-L0426
YAMAHA	YZ 80/85 02-	Z-L0339
	YZ(F)250 98-13, YZF450 98-09	Z-L0330/0423
	YZF 250/450 2014-	Z-L0367
	YZF 450 10-13	Z-L0362
	WR 250/450 03-06	Z-L0342
	YFZ Quad	Z-L0344Q
KTM	KTM SX 60/50 1998-	Z-L0810
	KTM SX 98-06, EXC 98-07	Z-L0817
	KTM SX(F) 07-10 EXC(F) 08-, Quad XC	Z-L0818
	KTM SX 50 2009-	Z-L0820
	KTM SX(F) 2011- 15, EXC 2012-	Z-L0822
	KTM SX 2016-, Husky TC 2016-	Z-L0823
HUSABERG	Husaberg 2009- 14	Z-L01108
HUSQUVARNA	Husqvarna 2T 125-360 92-04/ 4T 03-13	Z-L0606
BETA	Beta RR 250-525 alle -12	Z-L01505
	Beta RR 250/300/350/450/525 alle 13-	Z-L01507
GASGAS	GASGAS alle -2006	Z-L0110
	GASGAS alle 2007-	Z-L01407
SHERCO	Sherco 250/300/450 alle 12-	Z-L01812

ZAP LUFTFILTER GEÖLT airfilter oil

MODEL	NAME	# REF
HONDA	CRF 250 10-13/450 09-12	L3129OIL
	CRF 450 13-, CRF 250 14-	Z-L3132OIL
	RM 04-/RMZ 05-	Z-L3330OIL
KAWASAKI	KXF 250 06-16/450 06-15	Z-L3228OIL
	KXF 450 16-	Z-L3235OIL
YAMAHA	YZ(F)250 98-, YZF450 98-09	Z-L3330OIL
	YZF 250/450 2014-	Z-L3367OIL
KTM	SX(F) 2011-2015 EXC 2012-	Z-L3822OIL



WASCHABDECKUNG *airboxcover*

MODEL	NAME	# REF
HONDA	CR 80/85 (86-)	Z-AC2102
	CR 89-	Z-AC2106
	CRF 450 (02)	Z-AC2123
	CRF 250 03-09 / 450 03-08	Z-AC2125
	250 10-13 / 450 09-12	Z-AC2129
	CRF 450 13-, CRF 250 14-	Z-AC2132
SUZUKI	RMZ 04-06	Z-AC2227
	RM / RMZ	Z-AC2322
	RM 80/85 (86-)	Z-AC2402
	RM 125 -03 / 250 96-02	Z-AC2417
KAWASAKI	KX85 (91-)	Z-AC2216
	KX 125 / 250 02-	Z-AC2220
	KXF 250 04-05	Z-AC2227
	KXF 250 04- 450 04-15	Z-AC2228
	KXF 450 16-	Z-AC3016
YAMAHA	YZ(F) 125 / 450	Z-AC2322
	YZ 85 02-	Z-AC2339
	WR250 / 450F 03-06	Z-AC2342
	YZ(F) 450 10-13	Z-AC2362
	YZ(F) 2014-	Z-AC2367
KTM	KTM SX(F) 98-15, EXC 98- 16	Z-AC2822
	KTM SX(F) 16-	Z-AC5016
GASGAS	GasGas alle 2006	Z-AC2106

Schützt den Ansaugtrakt gegen das Eindringen von Wasser und Schmutz beim Waschen

Protects the intake system against the ingress of water and dirt during washing



Z-AC2102



Z-AC2106



Z-AC2123



Z-AC2125



Z-AC2129



Z-AC2132



Z-AC2216



Z-AC2220



Z-AC2227



Z-AC2228



Z-AC2322



Z-AC2339



Z-AC2342



Z-AC2362



Z-AC2367



Z-AC2402



Z-AC2417



Z-AC2822



Z-AC5016





SITZBEZÜGE *seatcover*

MODEL	NAME		COLOR	# REF
CR(F)	RIB-Grip	CRF 450 13-, 250 14-		Z-SC-10013RSRIB
	Factory-Grip	CRF 450 09-12, 250 10-13		Z-SC-10912SR
	Factory-Grip	CRF 450 13-, 250 14-		Z-SC-10013SS
	Factory-Grip	CRF 450 09-12, 250 10-13		Z-SC-10912SS
	RIB-Grip	CRF 450 13-, 250 14-		Z-SC-10013SRRIB
	Factory-Grip	CRF 450 13-, 250 14-		Z-SC-10013SR
	RIB-Grip	CRF 450 09-12, 250 10-13		Z-SC-10912SRRIB
RM(Z)	RIB-Grip	RMZ 450 08-		Z-SC-24814SWRIB
	Factory-Grip	RMZ 450 08-		Z-SC-24814SS
	Factory-Grip	RMZ 250 08-		Z-SC-22814SS
	RIB-Grip	RMZ 450 08-		Z-SC-24814SRRIB
	Factory-Grip	RMZ 250 08-		Z-SC-220814GS
	Factory-Grip	RMZ 450 08-		Z-SC-240814GS
	RIB-Grip	RMZ 250 08-		Z-SC-22814SRRIB
	RIB-Grip	RMZ 250 08-		Z-SC-22814SWRIB
KX(F)	RIB-Grip	KXF 250 13-, 450 12-		Z-SC-30014SWRIB
	RIB-Grip	KXF 250 13-, 450 12-		Z-SC-30014SGRRIB
	RIB-Grip	KXF 250 13-, 450 12-		Z-SC-30014GRSRIB
	Factory-Grip	KXF 250 09-12, 450 09-11		Z-SC-30911SS
	Factory-Grip	KXF 250 13-, 450 12-		Z-SC-30014SS
YZ(F)	Factory-Grip	YZF 250/450 14-		Z-SC-40014SB
	RIB-Grip	YZF 250/450 14-		Z-SC-40014BWRIB
	RIB-Grip	YZF 250/450 14-		Z-SC-40014SBRIB
	RIB-Grip	YZ 125/250/ 02-		Z-SC-4000BWRIB
	Factory-Grip	YZF 250/450 14-		Z-SC-40014SS
KTM	RIB-Grip	KTM SXF 125-450 11-		Z-SC-50011SORIB
	Factory-Grip	KTM SXF 125-450 11-		Z-SC-50011SS
	RIB-Grip	KTM SXF 125-450 11-		Z-SC-50011SBRIB



ZAP Factory-Grip
Sitzbezug



ZAP RIP-Grip
Sitzbezug

ZAP DREHZAHLMESSER UND BETRIEBSSTUNDENZÄHLER

sehr zuverlässig

- mit Drehzahlmesser
- speziell für Offroad Motorräder entwickelt
- zeigt Luftfilter-, Öl- und Ventilservice (5h, 10h, 20h) an
- stoß- und schlagfestes Kunststoffgehäuse, wasserdicht IP68
- LCD Display 12,7mm x 25,4mm
- mit ca. 8 Jahren Lebensdauer



RPM meter and hourmeter

- very reliable
- developed specifically for off-road motorcycles
- shows RPM, air filter-, valve- and oil service
- Shock and impact-resistant plastic housing, waterproof IP68
- LCD display 12.7 mm x 25.4 mm
- with about 8 years of life



OFFROAD VIBRATIONS- SERVICESTUNDEN-ZÄHLER kabellos, resetbar

sehr zuverlässig

- Stundenzähler zurücksetzbar
- kabellose Messung- über Vibration
- Sensibilität einstellbar
- speziell für Offroad Motorräder entwickelt
- zeigt max. Luftfilter-, Ventil- und Ölservice an
- stoß- und schlagfestes Kunststoffgehäuse, wasserdicht IP68
- LCD Display 12,7mm x 25,4mm
- mit ca. 5 Jahren Lebensdauer



Vibration RunTime-Meter resettable, wireless

- very reliable, - Resettable hour meter
- Cableless, vibration measurement
- adjustable sensibility
- developed specifically for off-road motorcycles
- shows air filter-, valve- and oil service
- Shock and impact-resistant plastic housing
- Waterproof IP68
- LCD display 12.7 mm x 25.4 mm
- with about 5 years of life

BETRIEBSSTUNDENZÄHLER hourmeter

NAME	COLOR	# REF
Offroad Service und Stundenzähler resetbar	■	Z-HM-BLACK
Offroad Service und Stundenzähler resetbar	■	Z-HM-BLUE
Offroad Service und Stundenzähler resetbar	■	Z-HM-ORAN
Offroad Service und Stundenzähler resetbar	■	Z-HM-RED

Offroad Service und Stundenzähler VIBRATION, resetbar	■	Z-HMVIB-BLACK
Offroad Service und Stundenzähler VIBRATION, resetbar	■	Z-HMVIB-BLUE
Offroad Service und Stundenzähler VIBRATION resetbar	■	Z-HMVIB-ORAN
Offroad Service und Stundenzähler VIBRATION, resetbar	■	Z-HMVIB-RED



HALTER FÜR BETRIEBSSTUNDENZÄHLER

hourmeter holder

	COLOR	# REF
Halter für Betriebsstundenzähler	■	Z-8024B
Halter für Betriebsstundenzähler	■	Z-8024GR
Halter für Betriebsstundenzähler	■	Z-8024R
Halter für Betriebsstundenzähler	■	Z-8024SI

ZAP KILLSCHALTER

– Killschalter in Originalform

ZAP killswitch

– kill switch in original shape

MODEL	NAME	# REF
HONDA	CR	Z-8014
	CRF 450 09-, CRF 250 10-	Z-8021
SUZUKI	RM	Z-8016
KAWASAKI	KX(F)	Z-8015
YAMAHA	YZF / YZ 125-250 05-	Z-8017
UNIIVERSAL	Killschalter/ Kombischalter Enduro	Z-8025



Z-8014



Z-8015



Z-8025



Z-8021



Z-8017



Z-8016

ABREISSKILLSCHALTER *dead man killswitch*

	# REF
Abreiß-Killschalter universal (Öffnerfunktion) Unterbrecher-Killschalter öffnet den Stromkreis wenn die Leine gezogen wird. z.B. für Minicross & Quad. Roter Nippel in der Lenkeraufnahme. <small>Dead man killswitch (opener function), opened the eletricial circuit.</small>	Z-80180
Abreiß-Killschalter universal (Schließerfunktion) schließt den Stromkreis wenn die Leine gezogen wird. z.B. für Minicross & Quad. Schwarzer Nippel in der Lenkeraufnahme. <small>Dead man killswitch (closer function), opened the eletricial circuit.</small>	Z-8018S





SLIDER KLEMME

CNC-gefräste Halteschelle für Bremsarmatur. Durch die eingearbeitete Nylonbuchse wird die Gefahr des Bruches der Armatur oder des Hebels bei einem Sturz verringert.

	# REF	COLORS
Slider Klemme	Z-8068B	
Slider Klemme	Z-8068O	
Slider Klemme	Z-8068R	
Slider Klemme	Z-8068S	

slider brakel

CNC-machined brakel for brake. The nylon bushing reduces the risk of a broken brake perch.



EDELSTAHL-GABELENTLÜFTERSET

Gabel schnell und einfach auf Knopfdruck entlüften!
Inhalt: 2 Stück

fork bleeders stainless steel

For quickly and easily bleeding the fork! Content: 2 pieces



NAME	# REF	COLORS
(WP/Marzochi) M4-Gewinde / thread	Z-8080O	
(WP/Marzochi) M4-Gewinde / thread	Z-8080R	
(WP/Marzochi) M4-Gewinde / thread	Z-8080B	
(WP/Marzochi) M4-Gewinde / thread	Z-8080TI	
(KYB/Showa) M5-Gewinde / thread	Z-8081R	
(KYB/Showa) M5-Gewinde / thread	Z-8081B	
(KYB/Showa) M5-Gewinde / thread	Z-8081TI	



ÖLEINFÜLLSCHRAUBE *oilcap*

	MODEL	# REF	COLORS
HONDA	CR, CRF450	Z-8090	R B
SUZUKI	RM, RMZ450 05-, RMZ250 07-	Z-8091	R
KAWASAKI	KX	Z-8090	R B
	KXF	Z-8093	R B
KTM		Z-8094	O B
YAMAHA	YZ(F)	Z-8090	R B

VORDERACHSMUTTER *front axel nut*

		# REF	COLORS
HONDA	CR(F)	Z-8125	R B
YAMAHA	YZ(F)	Z-8125	R B







STEUERKOPFMUTTER *steering head nut*

	MODEL	# REF	COLORS
HONDA	CR(F) 01-	Z-8126	R
	CR80-150	Z-8127	R B
	CRF50, KX+ RM+ YZ85, KX65	Z-8128	R
SUZUKI	RM(Z) 04-	Z-8127	R B
KAWASAKI	KX(F) 04-	Z-8129	R B
YAMAHA	YZ(F) 94-	Z-8127	R B
KTM	KTM EXC/SX 125-525	Z-8130	O
HUSKY	Husky 125-525 2014-	Z-8130	B

ÖLMESSSTAB *oil dipstick*

	MODEL	# REF	COLORS
CR(F)	CRF 250 -09	Z-8092	R
	CRF 250 10-	Z-8131	R
	CRF 450 09-	Z-8132	R



MODEL	# REF	COLORS	
CR(F) RM(Z) KX(F)	CRF 02-05, RMZ 250 07-09	Z-8082B	
	CRF 02-05, RMZ 250 07-09	Z-8082R	
	CR, KX(F) -05, RM(Z) -05, RMZ 10-	Z-8083B	
	CR, KX(F) -05, RM(Z) -05, RMZ 10-	Z-8083R	
CR(F) KX(F) YZ(F)	CRF 06-, KX(F), YZF 03-13	Z-8084B	
	CRF 06-, KX(F), YZF 03-13	Z-8084R	
KTM	SX -06, EXC-07, SX 85	Z-8085	

TANKDECKEL

- CNC-gefästes Aluminium
- farbig eloxiert
- inklusive Spezial-Dichtung







tank fuel caps

- CNC-machined aluminum
- color anodized
- includes special-gasket



TANKENTLÜFTUNGSVENTIL

tank ventilation valve

	# REF	COLORS
Tankentlüftungsventil	Z-8069B	
Tankentlüftungsventil	Z-8069G	
Tankentlüftungsventil	Z-8069O	
Tankentlüftungsventil	Z-8069R	
Tankentlüftungsventil	Z-8069S	
Tankentlüftungsventil	Z-8069SI	



GEMISCH-REGULIERSCHRAUBE

ermöglicht die Gemischeinstellung ohne Werkzeug



fuelscrew

With this screw you can adjust the air mixture in a few seconds!

	# REF	COLOR
Keihin	Z-8057R	



VERGASERDÜSEN-SETS

Carburetor jets

MODEL	# REF
Hauptdüsenset (10er) PWK – [150-172] main jet kit (10pcs) PWK - [150-172]	Z-10748
Hauptdüsenset (10er) PWK – [175-195] main jet kit (10pcs) PWK - [175-195]	Z-10749
Vergasernebendüsenset (10er) – Keihin/PWK Carburetor jet kit (10pcs) Keihin/PWK	Z-11023

BESCHLEUNIGERPUMPENDECKEL

- verhindert das „Verschlucken“ des Vergasers bei schneller Vollgasbewegung
- mehr Pumpenvolumen für mehr Leistung, für alle Keihin FCR Vergaser

acceleration pump cover

- engineered to get maximum fuel delivery and throttle response
- eliminating hesitation and bogging
- improves low-end performance and reduces hot engine stalling



	# REF	COLOR
Pump cover	Z-8095*	

*passt nicht bei CRF 06- / does not fit at CRF 06-



Z-BKK1B

bling kit - KTM/Husquarna

- Rear Axle Blocks
- Front Brake reservoir cap
- Rear Brake reservoir cap
- Oilfiller plugs
- Steering screw
- Rim Lock Nuts, washers and valve stem caps

BLING KIT - KTM/HUSQUARNA

- Bremszylinderdeckel vorn und hinten
- Lenkkopfschraube
- Öleinfüllschraube
- Reifenhalter-Muttern
- Ventilkappen



Z-BKK10

NAME	MODEL	# REF	COLORS
HONDA	CRF 250/450 09-	Z-BKH	
KTM	KTM EXC 07- 16, SX 07- 12	Z-BKK10	
YAMAHA	YZ250F 14- 16, 450F 10-	Z-BKY2B	
	YZ250F 14- 16, 450F 10-	Z-BKY2R	
	YZ250F 14- 16, 450F 10-	Z-BKY2S	
HUSQUARNA	TE 14- 16, TC 14- 15, Husaberg 11- 14	Z-BKK1B	

bling kit - japanische Modelle

- Rear Axle Blocks
- Front Brake reservoir cap
- Rear Brake reservoir cap
- Engine timing plugs
- Front Brake clip
- Rim Lock Nuts, washers and valve stem caps

BLING KIT - JAPANISCHE MODELLE

- Bremszylinderdeckel vorn und hinten
- Deckel für Inspektionsöffnungen
- Bremsleitungshalterung
- Reifenhalter-Muttern
- Ventilkappen



Z-BKH

ACHSENBLÖCKE axle blocks

MODEL	# REF	COLORS
KTM	KTM EXC 98-, SX(F) 98-12 20mm Achse axis	Z-8138
	KTM SX(F) 2013- 25mm Achse axis	Z-8139
HUSQVARNA	TE, TC, FE, FC, 20mm Achse axis	Z-8138
	TC, FC, 25mm Achse axis	Z-8139



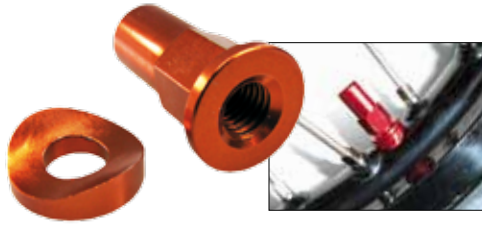

REIFENHALTER-MUTTERN

rimlock nuts

# REF	COLORS
Aluminium, für Reifenhalter / aluminium, for rim lock Z-8012	B O R S

DECKEL für

Cover for



HANDBREMSZYLINDER

hand brakereservior

MODEL	# REF	COLORS
HONDA CR(F) vorn / front	Z-8060	R B
SUZUKI RM, KX, YZ(F) -08 vorn / front	Z-8061	R B
YAMAHA YZ(F) 08- vorn / front	Z-8109	R B
KTM Brembo	Z-8063	O R B S
HUSKY ab 125 14-	Z-8113	R B S



FUSSBREMSZYLINDER

foot brakereservior

MODEL	# REF	COLORS
HONDA CR(F) 02-	Z-8064	R B
SUZUKI RMZ	Z-8065	R B
KAWASAKI KXF	Z-8065	R B
YAMAHA YZ(F) 03-, Beta -07 hinten / rear	Z-8067	R B
KTM ab 125 - 525 04-	Z-8113	O
HUSKY ab 125 14-	Z-8113	B



KUPPLUNGSZYLINDER

clutchreservior

MODEL	# REF	COLORS
KTM Brembo	Z-8063	O R B S
Magura 09- vorn / front (conical)	Z-8110	O



KUPPLUNGSZÜGE clutch cables

MODEL	NAME	# REF
HONDA	CR 125 (87-97)	Z-13012
	CR 125 (98-04)	Z-13022
	CR 80/85 (80-05)	Z-13032
	CR 250 (84-96)	Z-13042
	CR 250 (84-07)	Z-13052
	CRF 250 (04-09) 450 (04-08)	Z-13072
	CRF 250 (10- 13) 450 (09- 12)	Z-13082
SUZUKI	RM 125 (94-97) 250 (94-95)	Z-23012
	RM 125 (98-) 250 (01-)	Z-23022
	RMZ 250 (07-09)	Z-23042
	RMZ 250 (10-)	Z-23062
	RMZ 450 (08-)	Z-23032
	RMZ 450 (05-07)	Z-23052
KAWASAKI	KX 125 (99-02)	Z-33012
	KX 250 (99-04)	Z-33022
	KXF 250 (05-08), RMZ 250 (05-06)	Z-33032
	KX 80/85 (89-10)	Z-33042
	KXF 250 (09-10)	Z-33052
	KXF 450 (06-08)	Z-33062
	KXF 450 (09-14)	Z-33072
YAMAHA	YZ 125 (94-03)	Z-43022
	YZ 250 (88-98)	Z-43012
	YZ 250 (99-03)	Z-43032
	YZF/WRF 250-400-426	Z-43042
	YZF 250/450 (04-05)	Z-43052
	YZF 250 (06-08)	Z-43072
	YZF 450 (06-08)	Z-43062
	YZF 250/450 2014-	Z-4308
KTM	2-takt 250-380 (94-98)	Z-53021

GASZÜGE throttle cables

MODEL	NAME	# REF
HONDA	CR 125 (93-) 250 (93-03)	Z-13023
	CRF 250 (04-09) 450 (04-08)	Z-13033
	CRF 250 (10-) 450 (09-)	Z-13043
SUZUKI	RM 125/250 (97-04)	Z-23013
	RMZ 250 (07-09) 450 (05-07)	Z-23023
	RMZ 250/450 (08-)	Z-23033
KAWASAKI	125 (92-05) 250 (92-04)	Z-33013
	KX 80/85 (89-09)	Z-33023
	KXF 250 (04-10) 450 (06-08)	Z-33033
	450 (09-10)	Z-33043
YAMAHA	YZ 125 (96-06) 250 (96-05)	Z-43013
	YZ 85 (02-09)	Z-43023
	YZF 250 (03-08) 450 (03-09)	Z-43043
	YZF 250 (09- 13)	Z-43053
KTM	2-takt 125/380 98-12	Z-53013
	KTM 2-takt 85-300 13-	Z-53014
	KTM 4-takt (03-)	Z-53023
	KTM SX-F 250 (07- 12) EXC-F 250 (08- 12)	Z-53033



CARBON KETTENFÜHRUNG

- mit Hochglanz Finish
- sehr leicht, 50% Gewicht
- kein Verbiegen- sehr widerstandsfähig
- auch als günstiger Originalersatz zu verwenden

Carbon Chain Guide

- with high end finish
- light weight – 50%
- No bending-very resistant
- To be used OEM replacement



MODEL	# REF
CR(F)	CR 125/250 05-, CRF 250/450 05- Z-8146
KX(F)	Kawasaki KXF 250/450 09- Z-8147
YZ(F)	YZF 250/450 07-, YZ 125/250 08- Z-8148



CARBON GABELSCHUTZ

carbonfork savers

Gabelschutz aus Carbon, zum Schutz ihrer Standrohre
– passt universal an alle Upside- Down Gabeln

	# REF	COLOR
Länge ca. 25cm	Z-8026	■

NEOPREN GABELSCHUTZ

neopren fork savers

	# REF	COLOR
bis 50mm	Z-8032	■



HALTER BREMSLEITUNG VORN

brake hose clamp

MODEL	# REF	COLORS
CR(F)	Z-8123	B R
RM(Z)	Z-8124	B R
KX(F)	Z-8124	B R
YZ(F)	Z-8123	B R

STARTNUMMERN *start numbers*

1234567890

Standard Z-S1* + Z-S2*

1234567890

Standard Z-W1*

1234567890

RACING Z-S3* + Z-S4* + Z-S6*

**123456
67890**

US-STYLE Z-S5*

**123456
67890**

US-STYLE Z-W5*



ZAP GABELSTICKER

MODEL	# REF
Gabelstickerset / fork sticker KAYABA (pair)	ZI-KYB
Gabelstickerset / fork sticker SHOWA (pair)	ZI-SHO
Gabelstickerset / fork sticker KYB (pair)	ZI-KYB
Gabelstickerset / fork sticker ZAP 24x6cm (pair)	Z-GSS



STANDARD

NUMBER	■ 15 cm	■ 15 cm	■ 20 cm
1	Z-S1-1	Z-W1-1	Z-S2-1
2	Z-S1-2	Z-W1-2	Z-S2-2
3	Z-S1-3	Z-W1-3	Z-S2-3
4	Z-S1-4	Z-W1-4	Z-S2-4
5	Z-S1-5	Z-W1-5	Z-S2-5
6	Z-S1-6	Z-W1-6	Z-S2-6
7	Z-S1-7	Z-W1-7	Z-S2-7
8	Z-S1-8	Z-W1-8	Z-S2-8
9	Z-S1-6	Z-W1-6	Z-S2-6
0	Z-S1-0	Z-W1-0	Z-S2-0

RACING

NUMBER	■ 14 cm	■ 17 cm	■ 10 cm
1	Z-S3-1	Z-S4-1	Z-S6-1
2	Z-S3-2	Z-S4-2	Z-S6-2
3	Z-S3-3	Z-S4-3	Z-S6-3
4	Z-S3-4	Z-S4-4	Z-S6-4
5	Z-S3-5	Z-S4-5	Z-S6-5
6	Z-S3-6	Z-S4-6	Z-S6-6
7	Z-S3-7	Z-S4-7	Z-S6-7
8	Z-S3-8	Z-S4-8	Z-S6-8
9	Z-S3-6	Z-S4-6	Z-S6-6
0	Z-S3-0	Z-S4-0	Z-S6-0

US-STYLE

NUMBER	■ 15 cm	■ 15 cm
1	Z-S5-1	Z-W5-1
2	Z-S5-2	Z-W5-2
3	Z-S5-3	Z-W5-3
4	Z-S5-4	Z-W5-4
5	Z-S5-5	Z-W5-5
6	Z-S5-6	Z-W5-6
7	Z-S5-7	Z-W5-7
8	Z-S5-8	Z-W5-8
9	Z-S5-6	Z-W5-6
0	Z-S5-0	Z-W5-0

ZAP VAN STICKER

Randloser ZAP-Aufkleber für Ihren Van (geplotteter Schriftzug auf Trägerfolie) in 2 Größen.

Borderless ZAP sticker for your van (plotted lettering on support film) in various colors and sizes.

SIZE	# REF	COLORS
ZAP LOGO ca. 50x12cm	Z-VSSK	■ ■
ZAP LOGO ca. 115x27cm	Z-VSS	■ ■



ZAP SPANNGURTE SOFT HOOK - Made in USA

- extra starkes, langlebiges und witterungsbeständiges Gurtband
- wärmebehandelte, vinylbeschichtete Stahlhaken
- Softhaken um Kratzer zu vermeiden
- sehr vielseitig einsetzbar

Tie Downs ZAP Soft Hook - Made in USA

- extra strong and durable weather resistant webbing
- heat treated vinyl coated steel hooks
- soft hooks to prevent scratching
- very versatile in use

Z-6600-1G/1O/1R/1B



gefertigt in den USA

2-teilig, 40mm breit, 1,8m Länge
S-Haken mit Sicherung

manufactured in USA

ZAP Tie Downs, 40mm with Soft Hook
1,8m long, S-hooks with safety

MODEL	# REF	COLOR
2-tLg. 40mm breit	Z-6600-1B	■
2-tLg. 40mm breit	Z-6600-1G	■
2-tLg. 40mm breit	Z-6600-1O	■
2-tLg. 40mm breit	Z-6600-1R	■
2-tLg. 35mm breit	Z-6600	■

ZAP SPANNGURTE SOFT HOOK 2-teilig - Made in Germany

- erfüllt EN12195/2
- 2-teilig, 35mm breit, 1,8m Länge,
- S-Haken mit Sicherung

ZAP Tie Downs Soft Hook - Made in Germany

- meets EN12195/2
- ZAP Tie Downs, 35mm with Soft Hook, 1,8m long,
- S-hooks with safety,



Z-6600

ROLL OFF ZUBEHÖR

Roll-off Kanister links und rechts, Mudvisor Roll-off Film



roll off accessories:

Roll-off container (each for left side and each for right side)
mudvisor, Roll-off Film

	# REF	
ZAP Roll-off container links / left side	Z-ROL	■
ZAP Roll-off container rechts / right side	Z-ROR	■
ZAP Roll-off kit universal	Z-ROK	□
ZAP Roll-off mudvisor 3er	Z-ROV	
Roll-off Film SCOTT, SMITH	CC-RO10	

PDS-LAGER KIT *pds bearing kit*

	# REF
KTM, HUSABERG, VERTEMATI Mit 2 Dichtringen. Lager wartungsfrei mit Teflon-Gleitschicht. <i>With 2 sealing rings. Bearing maintenance free with teflon gliding surface.</i>	Z-PDSKIT

ZAP KETTENROLLEN *chain roller*

MODEL	# REF
42mm	Z-8007
32mm	Z-8008
HONDA CR(F)	Z-8111
KAWASAKI 06-	Z-8112
KTM alle	Z-8043



SCHRAUBEN und BUNDMUTTERN *screws and flange nuts*

MODEL	# REF
Schrauben / screws M6 x 12	Z-8045
Schrauben / screws M6 x 16	Z-8046
Schrauben / screws M6 x 20	Z-8047
Schrauben / screws M6 x 25	Z-8048
Bundmuttern / flange nuts M6	Z-8049
Bundmuttern / flange nuts M8	Z-8050



Z-8045 - Z-8050





- MX Lifter
- Top with PEHD plastic and grip tape
- wide feet for high stability
- max height 40cm, normal height 30cm, easy lift system
- factory Optics

BIKE STAND ZAP LIFT -LIGHT-

- MX Hub Ständer aus Stahl
- Auflage mit PEHD Plastik und Grip Tape
- breiter Fuss für hohe Standsicherheit
- leichtes Heben durch optimale Hubhebel-
übersetzung
- max Höhe 40cm, Standhöhe 30cm, 4,2 kg
- Factory Optik



	# REF	COLOR
Bike Stand ZAP Aluminium	Z-BSX	B R R

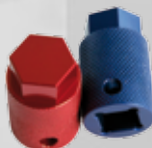
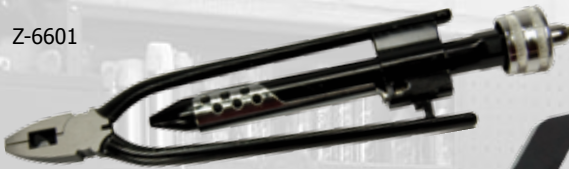
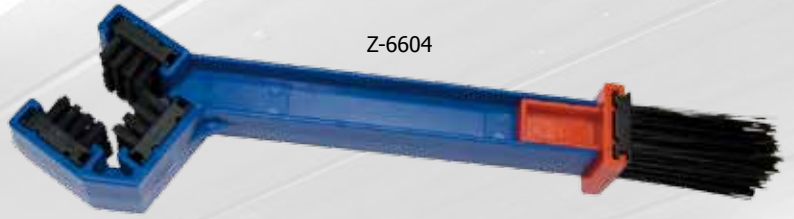
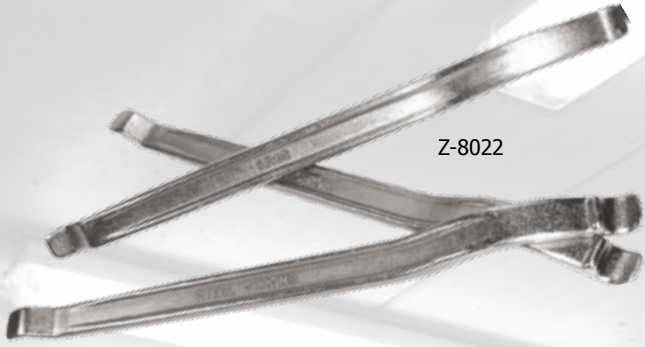



ZAP WERKZEUG

Für jeden Zweck zuverlässiges Zubehör!

ZAP tools

For any purpose reliable accessories!

MODEL	# REF
Drahtwirbelzange / wire twist pliers	Z-6601
Sicherungsdraht / safety wire for grips	Z-6602
Federnspanner / spring mounting tool	Z-6603
Kettenbürste / chain brush	Z-6604
Profi-T-Schlüssel 8mm / T-handle	Z-6606
Profi-T-Schlüssel 10mm / T-handle	Z-6607
Profi-T-Schlüssel 12mm / T-handle	Z-6608
Profi-T-Schlüssel 13mm / T-handle	Z-6609
Profi-T-Schlüssel 14mm / T-handle	Z-6610
Ventilausdreher / valve tool	Z-6612
3-Wege T-Schlüssel / 3-way T-handle 1/4+, 8, 10, 12, 13, X-Slot	Z-6613
Enduro universal Werkzeug / enduro universal tool	Z-6614
Reifenmontagehilfe / tire mounting buddy	Z-6615
Vorderachse Montage Werkzeug 19mm	Z-6618 R B
Cartridgeschlüssel KYB Sechskant, Gabelschlüssel 50 mm / forkwrench	Z-6619
Gabelschlüssel KYB Sechskant 49mm mit Federstopper Forkwrench 49 mm for WP forks closed Catridge	Z-8004
Gabelschlüssel Sechskant SW 50mm mit Federstopper für WP Gabel mit closed Catridge Forkwrench 50 mm for WP forks closed Catridge	Z-8005
Gabelschlüssel 47/50mm / forkwrench	Z-8006
Kettentrenner / chain breaker	Z-8009
Montiereisen / tire iron	Z-8022
Reifenluftdruckprüfer digital / wheel air pressure digital	Z-8027
Felgenschutz / plastic rim protector	Z-8044



REIFENHALTER *rim locks*

MODEL -PROfessional-	# REF
– Extra starker Metallkern – Teilweise Gummi ummantelt – extra heavy metal core – partly rubber coated	
1.40-1.60	Z-8001
1.85	Z-8002
2.15	Z-8003

MODEL -EXpert-	# REF
– Extra starker Metallkern – Vollkommen Gummi ummantelt – extra heavy metal core – fully rubber coated	
1.40-1.60	Z-8134
1.85	Z-8135
2.15	Z-8136



-EXpert- Z-8134 -36



-PROfessional- Z-8001 -03

AUSPUFF-FEDERN und -STOPFEN *exhaust springs and plugs*

	# REF
Auspuff-Feder / exhaust spring 99 mm	Z-8035
Auspuff-Feder / exhaust spring 83 mm	Z-8036
Auspuff-Feder / exhaust spring 75 mm	Z-8037
Auspuff-Feder / exhaust spring 57 mm	Z-8038
Auspuffstopfen / exhaust plug 2T	Z-8019
Auspuffstopfen / exhaust plug 4T	Z-8020



Z-8019 + Z-8020

Z-8035 - Z-8038

AUSPUFFWOLLE

- high performance Schalldämmwolle
- hitzebeständig bis 900 °C

exhaust wool

- high performance sound reduction wool
- heat resistant to 900°C

	# REF
Auspuffwolle / exhaust wool 400g	Z-SP400





Großhändler für die Marken:
wholesaler for brands:





ZAP TECHNIX GMBH

Waldecker Straße 8 | 99444 Blankenhain

Fon +49(0)36459 618040

Fax +49(0)36459 618049

www.zap-technix.com service@zap-technix.com

Redaktion: Falk Ziegler
Gestaltung: Isabell Berger, Falk Ziegler
Layout u. Satz: Isabell Berger
Druck: Druckhaus Gera GmbH

editorial staff: Falk Ziegler
design: Isabell Berger, Falk Ziegler
layout: Isabell Berger
printed by: Druckhaus Gera GmbH

Sämtliche in diesem Katalog enthaltenen Angaben entsprechen den zum Zeitpunkt der Drucklegung vorliegenden Informationen und dienen nur der Vorabinformation. Mögliche Farbabweichungen von Original-Produkten sind drucktechnisch bedingt. Aktuelle Preisinformationen erfahren Sie vom ZAP TechniX Team. Für Druckfehler keine Haftung. All informations contained in this brochure are correct at the time of printing informations and serve only as advance information. Color variations of original products are possible by the printing process. Pricing information can be found by contacting your ZAP TechniX team. No liability for printing errors.